



The Hartford Steam Boiler
Inspection and Insurance Co.
One State Street
P.O. Box 5024
Hartford, CT 06102-5024
Tel: 800-333-4677
Fax: 484-582-1811
Internet: <http://www.hsb.com>

Equipment Maintenance Checklist

OPERATION

Continued safe operation of your equipment depends on regular maintenance and testing of the equipment and its operating and protective controls. The tests and checks outlined below are designed to determine whether or not the equipment and controls are in good operating condition. The applicable log sheet should be used to guide you and document results.

REPAIRS

Should any check or test indicate that the device being tested or observed is not in good operating condition it should be repaired immediately. Record and maintain records of repairs or changes so that a complete record will be available for review at any time.

RECORDS

Equipment procedures and maintenance guidelines should be kept in a central location for quick reference when needed. If missing, request complimentary copies from manufacturer or maintenance contractor.

INSTRUCTIONS

Read and follow all manufacturers' guidelines and instructions for periodic service, maintenance and inspection of equipment and systems.

PREPARE!

You should have an emergency shutdown procedure for critical equipment. Educate key employees in these procedures.

DON'T WAIT FOR EQUIPMENT FAILURE!

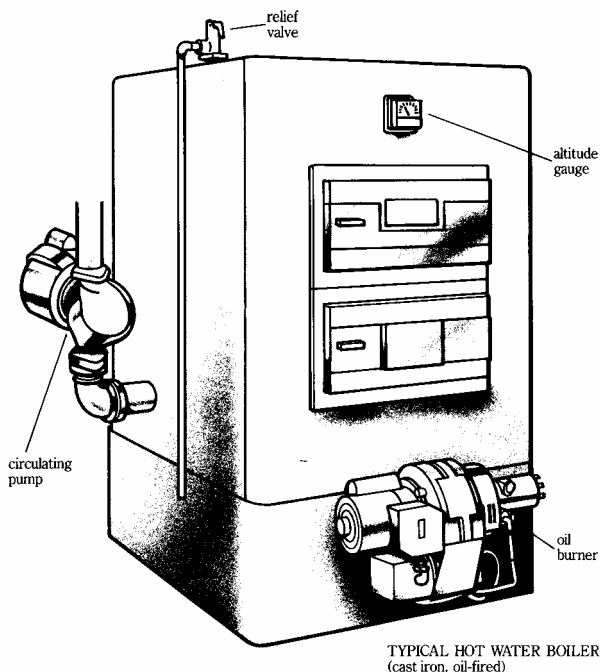

TYPICAL HOT WATER BOILER
(cast iron, oil-fired)

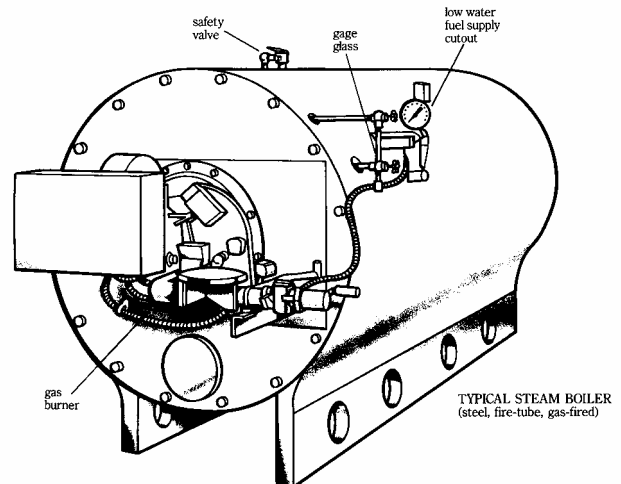

TYPICAL STEAM BOILER
(steel, fire-tube, gas-fired)

EQUIPMENT/SYSTEM	WHAT TO LOOK FOR/WHAT TO DO	Daily	Weekly	Monthly	Quarterly	Annually	REFERENCE DOCUMENT #
<p>STEAM HEATING HIGH PRESSURE Over - 15psi <i>Caution - All steam and water discharges must be piped to a safe place.</i></p>	<p>PUMP AND SYSTEM – Check feedwater and condensate pumps for proper operation and leaky packing. Examine traps, check valves, makeup float valves, expansion or condensate tank, and other parts of the system. LOW-WATER FUEL CUT-OFF – Drain float chamber while boiler is running. This should interrupt the circuit and stop the burner. BURNER OPERATION – If the burner starts with a puff or operates roughly, call your service personnel at once. SAFETY/RELIEF VALVE – Pull try-lever to full open position with pressure on the boiler. Release try-lever to allow the valve to snap closed. WATER COLUMN OR GAGE GLASS – Open the drain valve quickly to void a small quantity of water. Water level should return quickly when the drain valve is closed.</p>	<input type="checkbox"/>	<input type="checkbox"/>	<input type="checkbox"/>	<input type="checkbox"/>	<input type="checkbox"/>	<p>421 422 441</p>
<p>STEAM HEATING LOW PRESSURE 15psi and under <i>Caution – All steam and water discharges must be piped to a safe place.</i></p>	<p>PUMP AND SYSTEM – Check feedwater and condensate pumps for proper operation and leaky packing. Examine traps, check valves, makeup float valves, expansion or condensate tank, and other parts of the system. LOW-WATER FUEL CUT-OFF – Drain float chamber while boiler is running. This should interrupt the circuit and stop the burner. BURNER OPERATION – If the burner starts with a puff or operates roughly, call your service personnel at once. SAFETY/RELIEF VALVE – Pull try-lever to full open position with pressure on the boiler. Release try-lever to allow the valve to snap closed. WATER COLUMN OR GAGE GLASS – Open the drain valve quickly to void a small quantity of water. Water level should return quickly when the drain valve is closed.</p>	<input type="checkbox"/>	<input type="checkbox"/>	<input type="checkbox"/>	<input type="checkbox"/>	<input type="checkbox"/>	<p>401 423 442</p>
<p>HOT WATER HEATING 160°F & 250psi or less <i>Caution – All water discharge must be piped to a safe place.</i></p>	<p>PUMP AND SYSTEM – Check feedwater pump for proper operation and leaky packing. Examine check valves, makeup float valves, expansion, and other parts of the system. LOW-WATER FUEL CUT-OFF (if applicable) – Drain float chamber while boiler is running. This should interrupt the circuit and stop the burner. BURNER OPERATION – If the burner starts with a puff or operates roughly, call your service personnel at once. SAFETY/RELIEF VALVE – Pull try-lever to full open position with pressure on the boiler. Release try-lever to allow the valve to snap closed.</p>	<input type="checkbox"/>	<input type="checkbox"/>	<input type="checkbox"/>	<input type="checkbox"/>	<input type="checkbox"/>	<p>401 423 442</p>

BOILERS

EQUIPMENT/SYSTEM	WHAT TO LOOK FOR/WHAT TO DO	Daily	Weekly	Monthly	Quarterly	Annually	REFERENCE DOCUMENT #
<p>HERMETIC</p> <p><i>Caution - Always deenergize electrical equipment before testing, cleaning or performing maintenance.</i></p>	<p>MOTORS – Take insulation resistance readings of motor windings. If less than one megohm DO NOT start motor. Check for the cause of LOW RESISTANCE. NOTE: Hermetic motor readings less than 30 megohms should be checked by a service technician.</p> <p>MOTOR CONTROLS – Impact starter contacts for deterioration, pitting, corrosion, etc.; check terminal connections for tightness; examine overload protection for adequate size and defects; determine that timing devices have correct operating sequence; check mechanical linkage for binding and looseness.</p> <p>FANS – Check for broken, cracked, bent or loose blades or hubs; check shaft and bearings; check belt tension and condition.</p> <p>FILTERS – Clean air filters serving the evaporator and the air-cooled condenser. If a water-cooled condenser is used, the water side must be kept clean.</p>		<input type="checkbox"/>			<input type="checkbox"/>	<p>406 407 425 445 448</p>
<p>NON-HERMETIC</p> <p><i>Caution – Always deenergize electrical equipment before testing, cleaning or performing maintenance.</i></p>	<p>MOTORS – Take insulation resistance readings of motor windings. If less than one megohm DO NOT start motor. Check for the cause of low resistance. Check air ventilation openings on open-type motors for obstruction. Check bearings on open-type motors for adequate and proper lubrication.</p> <p>MOTOR CONTROLS – Inspect starter contacts for deterioration, pitting, corrosion, etc.; check terminal connections for tightness; examine overload protection for adequate size and defects; determine that timing devices have correct operating sequence; check mechanical linkage for binding and looseness.</p> <p>FANS – Check for broken, cracked, bent or loose blades or hubs; check shaft and bearings; check belt tension and condition.</p> <p>FILTERS – Clean air filters serving the evaporator and the air-cooled condenser. If a water-cooled condenser is used, the water side must be kept clean.</p> <p>MOISTURE INDICATOR – Observe to determine any change in the indicator chemical color or the presence of gas bubbles in the liquid refrigerant. In either case your service technician should be called.</p> <p>OIL SIGHT GLASS – Observe the glass to establish that sufficient oil is in the compressor crankcase. Oil leakage should not be tolerated. Any change in normal oil level should be investigated by your service technician.</p> <p>TEMPERATURE – In-operation temperature levels for the compressor suction and discharge should be established and recorded. Any unusual change in these temperatures should be called to the attention of your service technician.</p> <p>PRESSURE – Operating pressure levels should be established and recorded. Any unusual change in these pressures should be called to the attention of your service technician.</p>		<input type="checkbox"/>	<input type="checkbox"/>	<input type="checkbox"/>	<input type="checkbox"/>	<p>406 407 425 445 448</p>
AIR CONDITIONING & REFRIGERATION							

EQUIPMENT/SYSTEM	WHAT TO LOOK FOR/WHAT TO DO	Daily	Weekly	Monthly	Quarterly	Annually	REFERENCE DOCUMENT #
<p>ELECTRICAL DISTRIBUTION SYSTEM</p> <p><i>Caution - Always deenergize electrical equipment before testing, cleaning or performing maintenance.</i></p> <p>COOL – All vent and air circulation openings must be clear and operational. Electrical loads should be reviewed and corrected to ensure that circuits are properly loaded and balanced.</p> <p>CLEAN – Dust and/or dirt accumulations should be removed from the equipment and surroundings. Equipment should be thoroughly cleaned inside and outside. Space in switchrooms and switchgear enclosures should not be used for storing tools, supplies, or other material.</p> <p>DRY – Precaution should be taken to prevent steam, chemicals, moisture, or condensation from entering electrical enclosures.</p> <p>TIGHT – Clean and tighten all loose parts and replace any that are worn. Equipment should be manually exercised to established that moving parts do not bind and are free to operate.</p>	<p>420 443 446 447</p>		<input type="checkbox"/>	<input type="checkbox"/>	<input type="checkbox"/>		
<p>ELECTRONIC & COMPUTER EQUIPMENT</p> <p><i>Caution - Always deenergize electrical equipment before testing, cleaning or performing maintenance.</i></p> <p>PROTECTION – Computers, associated components of the computer system, and other electronic equipment should be protected by a UL-listed surge suppression device. Verify that vital programs and records are stored remotely and/or in an approved safe located in a low-hazard area, and protected by smoke detection and automatic sprinklers.</p> <p>HEAT – All vent and air circulation openings must be free from obstruction. Filters should be kept clean and sound, and the fans operable.</p> <p>SMOKE – Ensure that approved detectors are installed and maintained. Verify that the actuation of any detector results in the sounding of alarms and the shut down of air conditioning equipment.</p> <p>DRY – Precaution should be taken to prevent steam, chemicals, moisture, or condensation from entering Computers or associated equipment.</p>	<p>420 443</p>		<input type="checkbox"/>	<input type="checkbox"/>	<input type="checkbox"/>		
ELECTRICAL / ELECTRONIC							

EQUIPMENT/SYSTEM	WHAT TO LOOK FOR/WHAT TO DO	Daily	Weekly	Monthly	Quarterly	Annually	REFERENCE DOCUMENT #
FANS, BLOWERS & AIR INDUCTION LOUVERS	<p>FANS & BLOWERS – Check for broken, cracked, bent or loose blades or hubs; check shaft and bearings; check belt tension and condition.</p> <p>VENTS & LOUVERS – Inspect for damage and operation. Parts should be free of obstructions or blockage that would prevent proper intake for combustion air. Vents must not be blocked open; this may cause excessive cold air induction and possible freezing of vital systems.</p>	<input type="checkbox"/>	<input type="checkbox"/>	<input type="checkbox"/>	<input type="checkbox"/>	<input type="checkbox"/>	420 443
DEEPWELL PUMPS	<p>MOTORS – Take insulation resistance readings of motor windings. If less than one megohm DO NOT start motor. Check for the cause of low resistance. Check air ventilation opening on open-type motors for obstruction. Check bearings on open-type motors for adequate and proper lubrication.</p> <p>MOTOR CONTROLS – Inspect starter contacts for deterioration, pitting, corrosion, etc.; check terminal connections for tightness; examine overload protection for adequate size and defects; check mechanical linkage for binding and looseness.</p>	<input type="checkbox"/>	<input type="checkbox"/>	<input type="checkbox"/>	<input type="checkbox"/>	<input type="checkbox"/>	425
HOT WATER HEATERS	<p>RELIEF VALVE – Pull try-lever to full open position with pressure on the equipment. Release try-lever to allow the valve to snap closed. Caution – All discharges must be piped to a safe place.</p>	<input type="checkbox"/>	<input type="checkbox"/>	<input type="checkbox"/>	<input type="checkbox"/>	<input type="checkbox"/>	423
FOOD PREPARATION EQUIPMENT, PRESSURIZED COOKERS, STEAM KETTLES & APPLIANCES	<p>See "Commercial Cooking Equipment Cleaning & Maintenance procedures" wall-chart.</p>	<input type="checkbox"/>	<input type="checkbox"/>	<input type="checkbox"/>	<input type="checkbox"/>	<input type="checkbox"/>	438

REFERENCE DOCUMENTS VIA HSB.COM
 Reference documents for all of the above checklist items are available through HSB.com.

NATIONAL TOLL-FREE INSPECTION HOTLINE
 Inspection questions, requests for reference documents or status of scheduled inspections can be made directly to HSB's national Inspection Hotline.
 Telephone: 800-333-4677
 Fax: 800-292-4083
 E-mail: NSCINSP_hotline@hsb.com

Keep A Record of Your Service Contractors for Quick Reference

SERVICE CONTRACTOR	COMPANY	NAME	TELEPHONE	FAX
HEATING				
COOLING AND REFRIGERATION				
ELECTRICAL				
PLUMBING				
UTILITY				
OTHER				